

Silent TS2

Nr. 2930 0050 / 2930 1050

***Bedienungsanleitung
Instruction manual • Mode d'emploi
Istruzioni d'uso • Instrucciones para el servicio
Инструкция по эксплуатации
사용 설명서***



Silent TS2

Nr. 2930 0050 / 2930 1050

ENGLISH

EN

Content

1. Introduction.....	2
1.1 Symbols	2
2. Safety	3
2.1 Intended Use	3
2.2 Improper Use.....	3
2.3 Ambient Conditions for Safe Operation.....	3
2.4 Ambient Conditions for Storage and Transport.....	3
2.5 Hazard and Warning Information.....	3
2.5.1 General Information	3
2.5.2 Specific Information	4
2.6 Authorized Persons.....	4
2.7 Disclaimer	4
3. Product Description	4
3.1 General Description	4
3.1.1 Areas of Application	5
3.2 Components and Functional Elements	5
3.3 Scope of Delivery	6
3.4 Accessories.....	6
4. Setting Up	7
4.1 Unpacking.....	7
4.2 Setup	7
4.2.1 External Exhaust Air Route	7
4.3 Electrical Connection.....	7
4.4 Compressed Air Connection.....	7
4.5 Installing the Pinch Valves	7
4.5.1 Suction Pipe Alteration	8
4.6 Connection to the Extraction Point.....	8
4.7 Electrical Connection.....	9
5. Operation	9
5.1 Switching the Unit On	9
5.1.1 Stand-By	9
5.2 Operation.....	9
5.2.1 Extraction	9
5.2.2 Extraction force	10
5.3 Programming	10
5.3.1 Self Diagnosis	11
5.3.2 Audible Signal	11
5.3.3 Dust Bag Full.....	11
5.3.4 Start-Up Threshold	12
5.3.5 Shut-Off Delay	12
6. Cleaning / Maintenance.....	13
6.1 Replacing the Dust Bag	13
6.2 Filters.....	14
6.2.1 Replacing the Fine Particle Filter	14
6.2.2 Replacing the Exhaust Filter	14
6.2.3 Replacing the Electronics Filter	15
6.2.4 Change Compressed filter	15

6.3	Self-Diagnosis.....	15
6.4	Safety Mechanism	15
6.5	Factory Set Parameter.....	15
6.6	Spare Parts	16
7.	Troubleshooting.....	16
7.1	Error codes	17
8.	Technical Data	18
9.	Warranty.....	19
10.	Disposal Information	19
10.1	Disposing of Consumables	19
10.2	Disposing of the Unit	19
10.2.1	Disposal Instructions for countries in the EU.....	19

1. Introduction

1.1 Symbols

In the instructions for use and on the unit itself you will find these symbols with the following meanings:



Danger

This indicates a direct risk of injury. Consult accompanying documents!



Electrical current

This indicates a risk of hazard due to an electrical current



Attention

Disregarding this warning may result in damage to equipment.



Note

This provides the operator with useful information to improve and ease use.



The device complies with the requirements of the applicable EU directives.



The device is subject to the EU directive 2002/96/EG (WEEE directive).

► **List, particular attention should be paid**

- List

⇒ Instructions / appropriate action / input / operational sequence:

You will be asked to carry out the action in a specified order.

◆ Result of an action / reaction of the device / reaction of the program:

The unit or program reacts as a result of your actions or when a specific incident occurs.

Other symbols are explained as they occur.

2. Safety

2.1 Intended Use

This device is designed to extract dry, non-explosive dust.

This device is intended solely for commercial use in a dental laboratory.

The intended use also includes compliance with the instructions specified by the manufacturer concerning operation, servicing and maintenance.

2.2 Improper Use

Fire promoting, easily flammable or explosive materials must not be extracted with the Silent TS2.

The extraction of liquids, smoldering or burning materials is prohibited.

This device is not intended for private, household use.

Any use other than specified in these instructions is deemed improper and constitutes a misuse of the device. The manufacturer shall not be liable for damages caused by improper use.

This device may only be serviced with accessories and spare parts supplied by the company Renfert. The use of other equipment is deemed as improper and carries the risk of serious injury.

2.3 Ambient Conditions for Safe Operation

The device may only be operated:

- Indoors
- Up to an altitude of 2,000 m above sea level,
- At an ambient temperature of between 5 - 40°C [41 - 104°F] *),
- At a maximum relative humidity of 80% at 31°C [87.8°F], dropping to a linear of up to 50% relative humidity at 40°C [104°F] *),
- With mains power where the voltage fluctuations do not exceed 10% of the nominal value,
- Under contamination level 2 conditions,
- Under over-voltage category II conditions,

*) Between 5 - 30°C [41 - 86°F] the device can be operated at a relative humidity of up to 80%. At temperatures between 31 - 40°C [87.8 - 104°F] the humidity must decrease proportionally in order to ensure operational readiness (e.g. at 35°C [95°F] = 65% humidity, at 40°C [104°F] = 50% humidity). The device may not be operated at temperatures above 40°C [104°F].

2.4 Ambient Conditions for Storage and Transport

For storage and transport the following specifications to ambient conditions apply:

- Ambient temperature -20 – +60°C [-4 – +140°F].
- Maximum relative humidity 80%

2.5 Hazard and Warning Information



2.5.1 General Information

- ▶ If the device is not used in compliance with the supplied instructions, the safety of the device can no longer be guaranteed.
- ▶ The device may only be operated using a mains cable with the country-specific plug system. Any necessary alterations must be carried out by a qualified electrician.
- ▶ The device may only be operated if the information on the identification plate conforms to the specifications of your local mains power supply.
- ▶ The device may only be plugged into outlets which are connected to the protective conductor system.
- ▶ The mains plug must be easily accessible.
- ▶ Disconnect the device from the mains before carrying out work on the electrical parts.
- ▶ Check connection cables (such as power supply cords), tubes and housing (i.e. the key-pad) regularly for damage (i.e. kinks, cracks and porosity) or signs of ageing.
- ▶ Devices with damaged connection cables, tubes or housing parts or other defects must not be operated!
- ▶ Defective devices must be put out of service immediately. Remove the mains plug and ensure the device is not used. Send the device for repair!

- ▶ Only operate the device under supervision.
- ▶ The use of unauthorized accessories may be an impediment to the safety of the device.
- ▶ Use spare parts and accessories supplied by Renfert only.
- ▶ Observe the accident prevention regulations by the trade association!
- ▶ It is the responsibility of the operator that national regulations during operation and regarding a repeated safety inspection of electrical equipment are complied with.
For Germany these are BGV A3 in relation with VDE 0701-0702.

2.5.2 Specific Information

- ▶ The mains socket on the device is only designed for purposes specified in the operating instructions. Connecting other devices may cause material damage.
- ▶ Before connecting another electrical appliance to the mains socket, switch the unit off.
- ▶ Read the operating instructions of the other appliance and comply with the safety instructions contained in the document.
- ▶ Please observe the national regulations and permitted exposure to dust in a working environment. Please ask the “National Institute for Occupational Safety and Health” or other responsible authority.
- ▶ Always refer to the relevant safety data sheets, when extracting hazardous materials,
- ▶ Always wear protective gear, when extracting hazardous materials.
- ▶ It is necessary to wear suitable personal protective equipment when emptying the dust drawer or cleaning, depending on the type of extracted material.
- ▶ When disposing of the extracted material or used filter, please observe the local specifications and accident prevention regulations!
- ▶ Make sure the dust drawer is fully closed during operation.
- ▶ Do not operate without a suction hose.
- ▶ Do not extract flammable or explosive gasses, fumes or dust.
- ▶ Do not extract hot materials.
- ▶ Do not extract liquids.
- ▶ If the dust extractor is employed to extract hazardous materials, appropriate personal protective gear must be worn and steps must be taken to ensure that the exhaust air is properly ventilated. Please refer to the associated safety data sheets for specific requirements.
- ▶ Dispose of extracted material according to local statutory regulations.

2.6 Authorized Persons

Operation and maintenance of the device may only be performed by qualified personnel.

Minors and pregnant women may only operate and service the device if they are wearing appropriate protective gear, in particular if the device is being used to extract hazardous materials.

Any repairs not specifically described in these operating instructions may only be carried out by a qualified electrician.

2.7 Disclaimer

Renfert GmbH shall be absolved from all claims for damages or warranty if:

- ▶ The product is employed for any purposes other than those specified in the operating instructions.
- ▶ The product is altered in any way other than those alterations described in the operating instructions.
- ▶ The product is not repaired by an authorized facility or if non-original Renfert parts are implemented.
- ▶ The product continues to be used despite obvious safety faults or damage.
- ▶ The product is subjected to mechanical impacts or is dropped.

3. Product Description

3.1 General Description

This device is a workbench extraction unit for the extraction of dusts generated in a dental laboratory. The extraction unit compiles two suction hoses to which one extraction point each may be connected. The extraction unit can be operated both manually and automatically, depending on the connected, electrical, dust-generating equipment.

3.1.1 Areas of Application

In the dental laboratory different areas of application are possible.

Depending on the amount of dust to be extracted and the extraction performance available, both suction hoses can either operate together, or if preferred, each tube alternately.

Area of application	
Standard Workbench (WB)	Grinding, separating, polishing, etc. of different dental materials such as alloys, acrylics, porcelains, plasters, etc. in normal amounts using the technician's hand piece.
Work Preparation (WP)	Mainly grinding plasters and acrylics in large amounts using the technician's hand piece
Device (D)	Dust intensive devices such as the fine/recyclable sandblaster, etc.

EN

Recommended use of the suction hoses:

WB + WB	Suction hoses A and B simultaneously
WB + WP	Suction hoses A and B simultaneously
WP + WP	Suction hose A or B alternately
D + D	Suction hose A or B alternately
WB + D	Suction hose A or B alternately
WP + D	Suction hose A or B alternately

3.2 Components and Functional Elements

- | | |
|--------------------------------|---|
| 1 Silent TS2 | 12 Compressed air connection with compressed air filter (Compressed air tube is sealed) |
| 2 Key-pad | 13 Motor compartment cover |
| 3 On / off switch | 14 Exhaust air filter |
| 4 Front panel/ Fine filter | 15 Pinch valve with extractor connection fitting (rotatable) |
| 5 Front panel/ Dust drawer | 16 Suction pipe |
| 6 Fine filter | 17 Connection set |
| 7 Dust drawer | 18 Suction hose (not included in the scope of delivery) |
| 8 Mains cable | |
| 9 Device coupler socket (A, B) | |
| 10 Device protection switch | |
| 11 Electronic filter | |

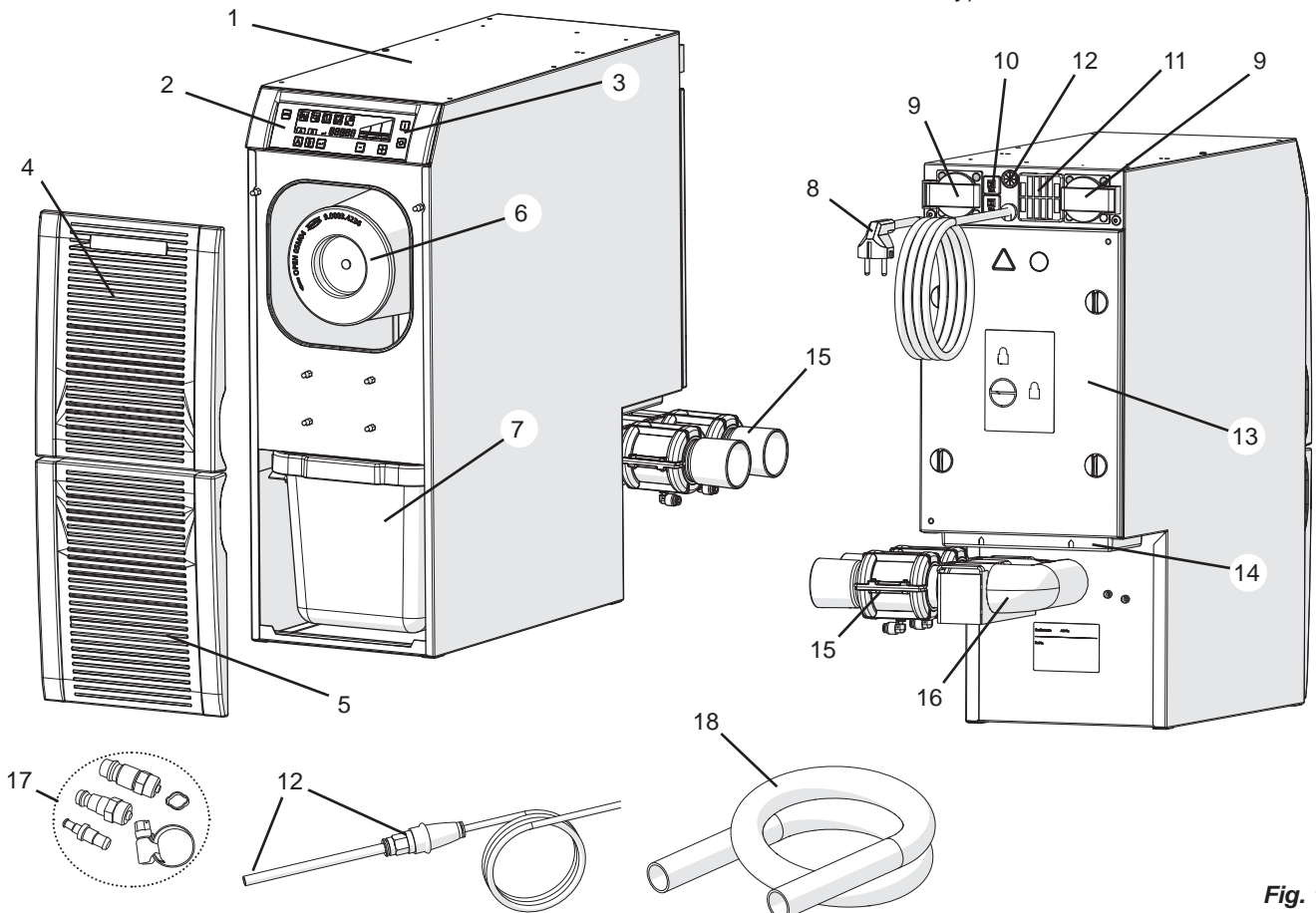



Fig. 1

- 3 On/off switch
- 30 Menu key
- 31 Self-diagnosis on/off
- 32 Audible signal on/off
- 33 Programming dust drawer full
- 34 Programming start-up threshold
- 35 Programming shut off delay
- 36 7 segment display
- 37 Suction level display
- 38 Suction hose display
- 39 Suction hose keys
- 40 Enter button, save input / display enter button
- 41  Button / display function button
- 42 Display factory setting
- 43  Button / display function button

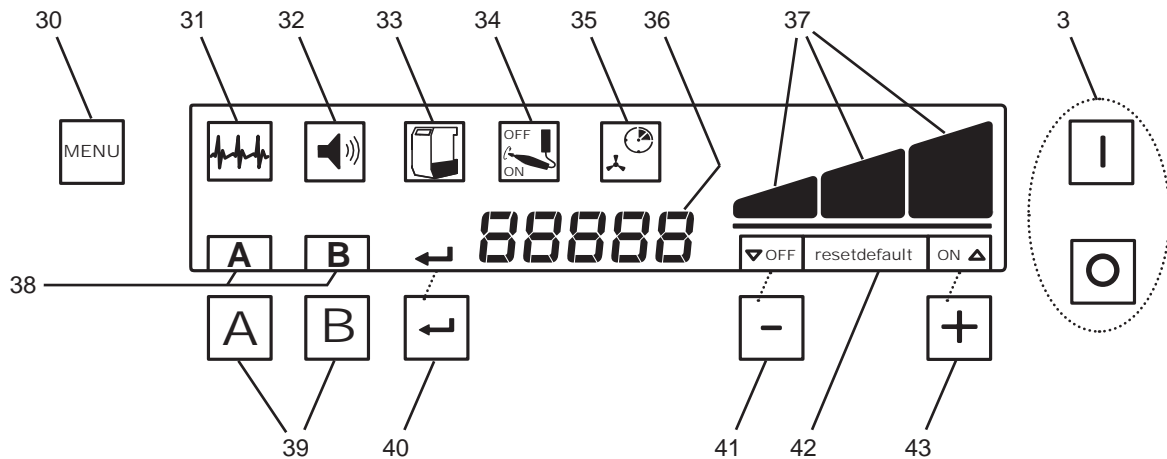

Fig. 2

3.3 Scope of Delivery

- 1 Silent TS2
- 1 Operating instructions
- 1 Quick reference card
- 1 Dust bag (ready for us in the dust drawer)
- 1 Compressed air tube (sealed)
- 2 Pinch valves with suction port
- 1 Connection set
- 2 Shockproof plug (only for 2930-0050)

3.4 Accessories

- 2921 0002 Dust bags (5 pieces)
- 2921 0001 Set of rollers
- 2925 0000 Extractor clamp (without glass screen)
- 2925 1000 Glass screen with holder (for the extractor clamp)
- 2921 0003 Set of mufflers, 2 pieces
- 2921 0004 External exhaust air control
- 90003 4305 Tube support adapter
- 90003 4240 Suction hose (3m)
- 90115 0823 Suction hose (6m)
- 90215 0823 Suction hose (9m)
- 90003 4410 H+Hepa filter
- 90003 4430 Suction hose adapter universal

4. Setting Up

4.1 Unpacking

- ⇒ Remove the device and all the accessories from the delivery package.
- ⇒ Check the delivery for completeness (refer to the “Scope of Delivery” section).

4.2 Setup

The extraction unit is a free-standing appliance, intended to be set-up on the floor (e.g. under the work-bench).

It is possible to connect up to two suction points.
Position the extraction device so that:

- The exhaust vent (14, fig.1) is not blocked.
- The distance to the suction points is approximately even.
- The front of the device is easily accessible for removal of dust drawer.

If the device is to be installed in a cabinet, an opening for the exhaust air with the following dimensions must be provided, in addition to the openings for the suction hoses:

- Circular opening: Min. 120 mm diameters
- Rectangular opening: Min. 170 x 65 mm

4.2.1 External Exhaust Air Route

An external exhaust air route (see accessories) allows the extracted air to leave the laboratory. The installation details are supplied with the external exhaust air route.

4.3 Electrical Connection



Before connecting the device, ensure that the voltage information on the identification plate corresponds with your local power supply.



Arrange the conducting parts (plug sockets, plugs and couplings) and install the extension cord so that the protection class is retained.

- ⇒ Switch the device OFF at the On / Off switch (3, fig.1)
- ⇒ Insert the mains cable into the plug socket.

4.4 Compressed Air Connection

The suction hoses are opened and closed via the pneumatic pinch valves (15, Fig.3). For this, compressed air is necessary. On the device, the compressed air tube is sealed. Connection to the compressed air supply:

- ⇒ Select the appropriate tube connection piece from the connection set (17, fig. 1) and attach to the end of the tube.
- ⇒ Connect to the compressed air.



Observe the minimal / maximum connection pressure, see technical data!



Compressed air should be clean and dry (without condensed water). Wet compressed air can damage the unit

4.5 Installing the Pinch Valves

In order to prevent damage during transport, the following parts
- pinch valves (15)
- suction pipe (16)
- holder (20)

are not mounted on the device, but will be delivered in a pre-assembled state.

- ⇒ These must be installed onto the device before use:
- ⇒ Unscrew the knurled head screw (19, Fig. 4a).
- ⇒ Push the suction pipe (16) onto the suction support on the

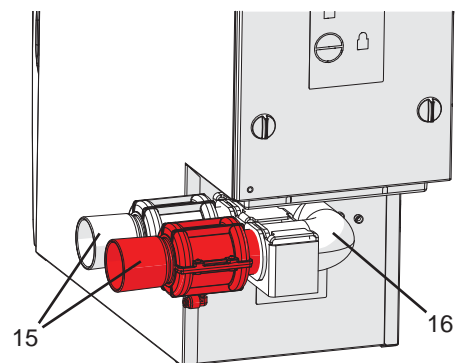

Fig. 3

- extractor and hang the holder (20) onto the holder screws (26, fig. 4b).
- ⇒ Fix the holder in place with the knurled head screw (19, fig. 4a).
- ⇒ Connect the compressed air tubes to the pinch valves:
 - Ensure the compressed air tubes (A, B) are connected to the correlating suction pipes (A, B).
 - Push the compressed air tube onto the pipe connection in the pinch valve as far as it will go. There will be a slight resistance to overcome when attaching.

4.5.1 Suction Pipe Alteration

! During the alteration, make sure that the compressed air tube is not unintentionally ripped away from the pinch valves. If possible, loosen before the alteration (press the ring at the compressed air connection and pull the tube towards you) and tighten again after the work has finished.

- ⇒ Pull the pinch valves out of the suction pipe.
- ⇒ Unscrew the knurled head screw (19).
- ⇒ Loosen the suction pipe (16) and the holder (20) from the holding screws by turning and then at the back, remove from the extractor connection (26) fitting (A).
- ⇒ Lever the suction pipe out of the holder (B), turn (C), and replace back into a new position in the holder (D).
- ⇒ Insert the suction pipe into the extractor connection fitting on the extraction device, hang (E) the holder into the holding screws (26).
- ⇒ Fix the holder with the knurled head screw (19).
- ⇒ Push the pinch valve (15) into the suction pipe (16) as far as it will go. This process is made easier by turning slightly when pushing into place.

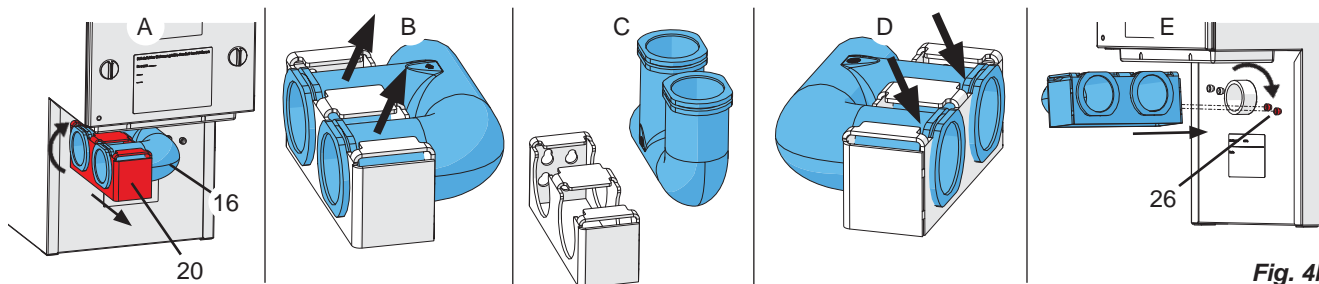

Fig. 4b

4.6 Connection to the Extraction Point

The extraction point is at the extractor connection fitting (15).
The “pinch valve with extractor connection fitting” is rotatable.

! When you turn the pinch valve, please ensure that there are no kinks in the compressed air tubes and that they are not unintentionally ripped off!

The compressed air tubes are marked with A and B so that they can be easily allocated to the relevant suction hoses. If necessary, turn the pinch valve with the extractor connection fitting (15) in the direction required.

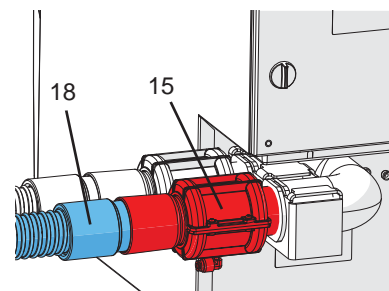

Fig. 5

- ⇒ Insert the suction hose (18, not included in delivery) into the extractor connection fitting (15).
- ⇒ Please use a hose connection adapter (see accessories) if the diameter sizes are different, in order to minimize ambient noise and loss of extraction force.
- ⇒ Attach the suction hose to the extraction point (e.g. Dustex master plus, extractor clamp, etc.).

i Long suction hoses, tight bends and kinks will considerably reduce the extraction force at the extraction point.

i If different suction hose lengths are used, the extraction force will be lower at the extraction point with the longer hose..

i Make sure that the suction hoses are the same length and diameter. Excess hose can be cut to size or laid in a large arch.

i Avoid steep pitches or hanging points along the hose path.

4.7 Electrical Connection

⇒ Electrical appliances can be connected to the coupler sockets (9, Fig.1) at the back of the unit. Check the connections are correct - coupler socket (A, B) - suction hose/pinch valve (A, B).



When connecting electrical appliances to the extraction unit, please ensure that the power consumption of all devices connected to the unit power outlet does not exceed the total maximum power for connected equipment (see chapter 8, “tech. Data”).



**A two pole plug with protective contact is available for use as an adapter. This adapter may only be put together by an electrician!
The protective conductor system must not be interrupted by the adapter!**

5. Operation

The extractor unit is operated via the buttons on the key-pad (2, fig.1).

5.1 Switching the Unit On

The extractor is switched ON and OFF at the On / Off switch (3)
When the unit is switched on, a self-diagnosis (See chapter 6.3) is performed (if activated) before the extractor changes to the stand-by mode.

From the stand-by mode the unit can be changed to:

- Operation, e.g. suction using one or both hoses (See chapter 5.2).
- Programming (See chapter 5.3).
- Stand-by mode (See chapter 5.1.1).

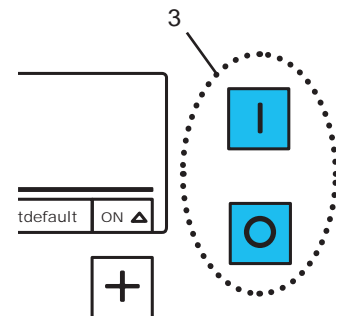

Fig. 6

5.1.1 Stand-By

In the stand-by mode the display is dark.

Change to the stand-by mode:

- If no button has been pressed and no suction hose is open for a period of 2 min.

Leave stand-by mode:

- Press any button
- Switch on any electrical appliance connected to the extractor.

Once switched on, the suction hose will open immediately and the extractor turbine will activate.

5.2 Operation

5.2.1 Extraction

When the extractor is switched on it goes to the stand-by mode.

When a suction hose is opened, the suction turbine switches to the last selected extraction force and the correlating pinch valve opens. When the second suction hose is then opened, the second pinch valve also opens.

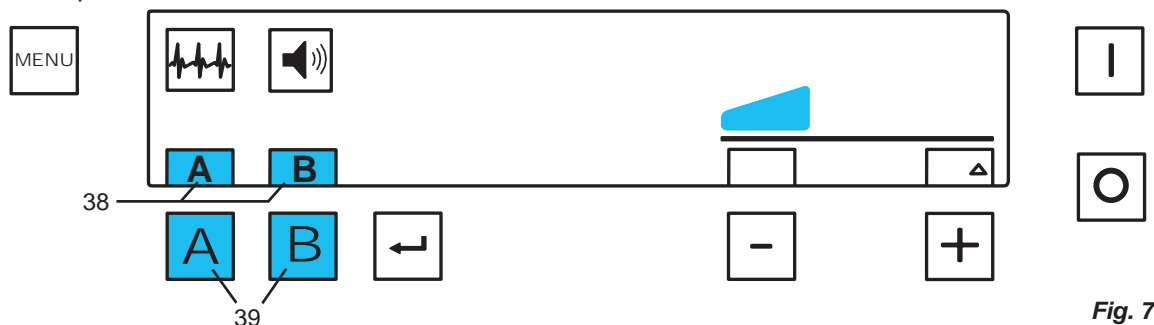

Fig. 7

Opening / closing of the suction hose is as follows:

- Automatically:
The electrical appliance connected to the coupler socket (9, fig. 1) is activated / deactivated.
- Manually:
By pressing a suction hose button (39).

The letters of the opened suction hose will be shown in the display (38).

If the electrical appliance is active, the relevant suction hose CANNOT be closed manually with the suction hose button, instead only by switching the electronic equipment off.

5.2.2 Extraction force

The extraction force can be adjusted in three levels; the current extraction force is shown in the display (37).

Set the extraction force:

- ⊕ Button (43), increases extraction force
- ⊖ Button (41), reduces extraction force

Readjustment of the extraction force:

The set extraction force applies for both suction hoses. When another suction hose is opened or closed, the power in the suction turbine is automatically readjusted so that the selected extraction force may be achieved in each opened suction hose.

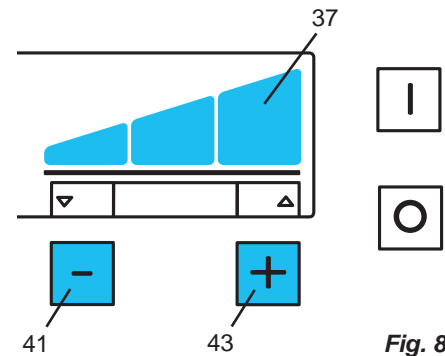

Fig. 8

To deactivate the extraction force readjustment:

In the stand-by mode:

⇒ Press ⊕/⊖ buttons (43/41) together for 3 seconds.

The indicator above the button ⊖ (41) shows "OFF".

The deactivated extraction force readjustment is shown by the "OFF" indicator above the button ⊖ (41) permanently.

To activate the extraction force readjustment:

In the stand-by mode:

⇒ Press ⊕/⊖ buttons (43/41) together for 3 seconds.

- ◆ The indicator above the button (41) goes out.

i *When the extraction force readjustment is deactivated, the extraction power on one suction hose will reduce considerably if a second suction hose is then also activated.*

i *On extraction force level "3" with both hoses open, only a reduced extraction power is available as the suction turbine cannot be increased any further.*

i *The fuller the dust bag, the lower the extraction performance.*

5.3 Programming

The menu function enables various extractor settings to be preset and saved.

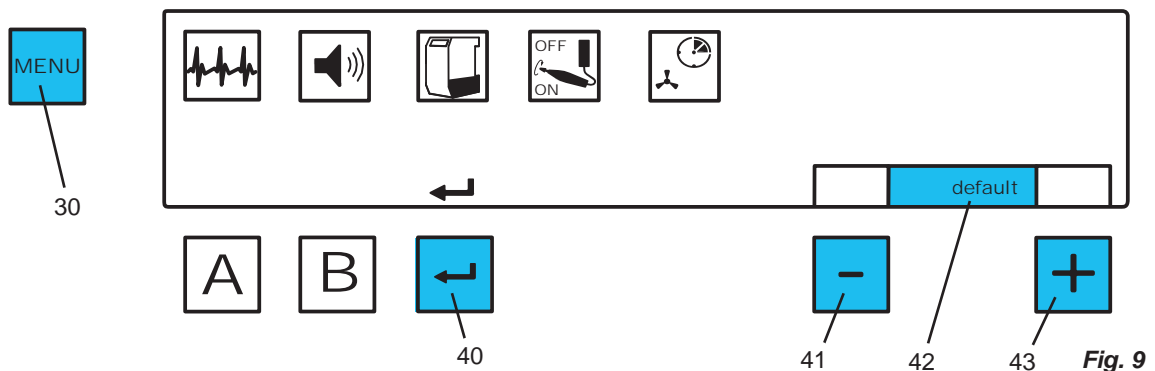

Fig. 9

In order to set different parameter, press the menu key (30) repeatedly.

To confirm and save the adjusted settings press the enter button (40).

An audible signal confirms that the settings have been successfully saved.

If you do not wish to save the adjustments, press the menu key again (30) and the programming will be aborted.

If the word "default" is shown in the display (42) press the buttons ⊕ and ⊖ (41, 43) together to revert to the standard factory settings (see table in chapter 6.5).

5.3.1 Self Diagnosis

The diagnosis symbol (31) shows whether the self diagnosis has been activated or not:

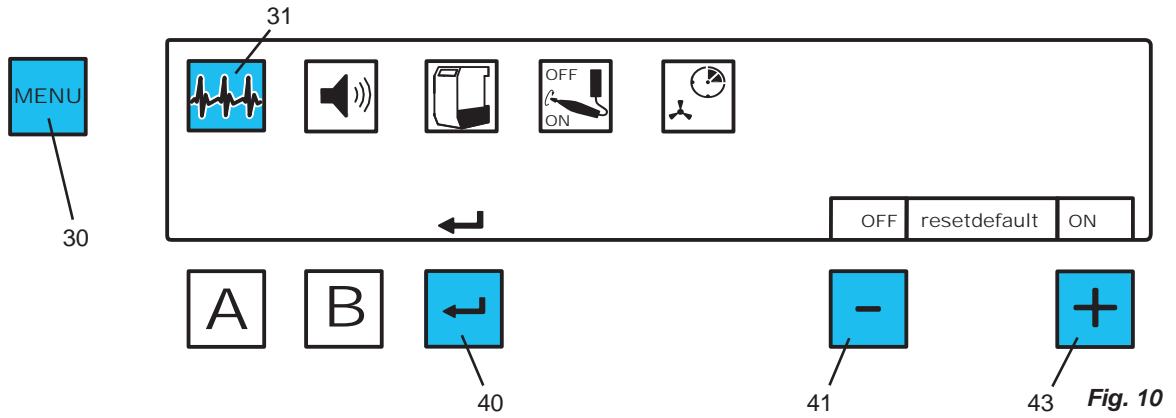

Fig. 10

⇒ The diagnosis symbol (31) shows whether the self diagnosis has been activated or not:

- ◆ Press menu key (30) 1x
- ⇒ The diagnosis symbol (31) blinks
- ⇒ Switch the self diagnosis ON or OFF using the ⊕/⊖ buttons (41, 43)
- ⇒ Press the enter button (40).

5.3.2 Audible Signal

Various settings and warnings are confirmed or alerted via an audible signal. This signal can be switched on or off. The audible signal symbol (32) shows whether the signal is on or off.

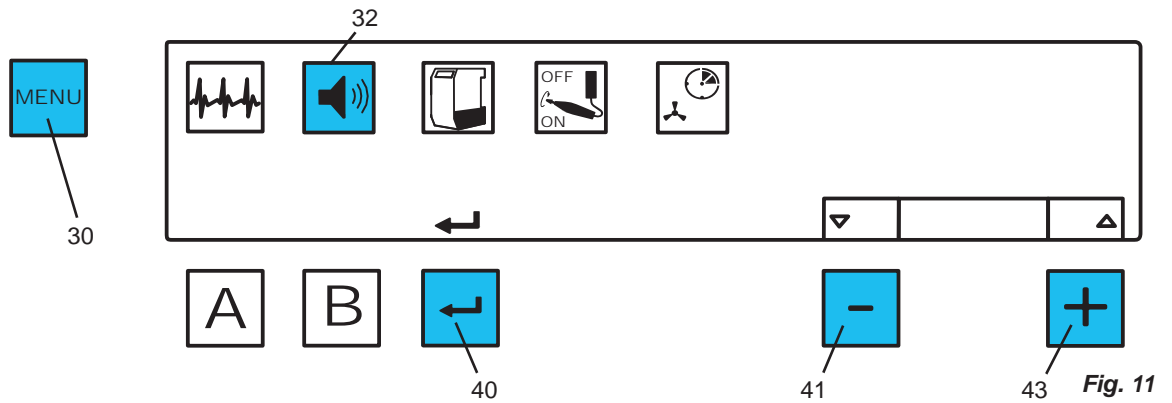

Fig. 11

- ⇒ Press menu key (30) 2x
- ◆ The audible signal symbol (32) blinks
- ⇒ Switch the self diagnosis ON or OFF using the ⊕/⊖ buttons (41, 43)
- ⇒ Press the enter button (40).

5.3.3 Dust Bag Full

A full dust bag is indicated by the dust drawer symbol (33).



The fill level of the dust bag depends on the type of dust accumulated.

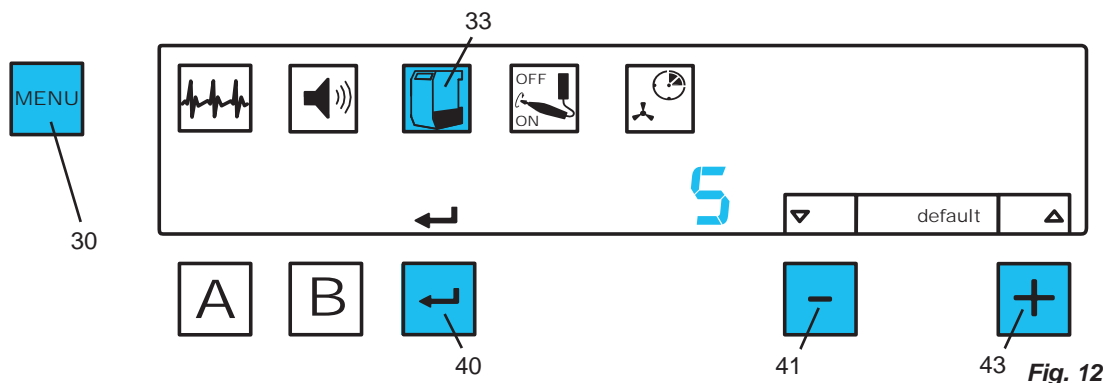

Fig. 12

The sensitivity of the “dust bag full” indication can be changed. This will also change the fill level within the dust bag, or duration until the signal “dust bag full” is shown.

- ⇒ Press menu key (30) 3x
 - ◆ The dust drawer symbol (33) blinks
 - ◆ The set sensitivity level is shown.
- ⇒ Change the level using the / buttons (41, 43):
 - ◆ 1: full
 - ◆ 9: low fill level
- ⇒ Press enter button (40).

5.3.4 Start-Up Threshold

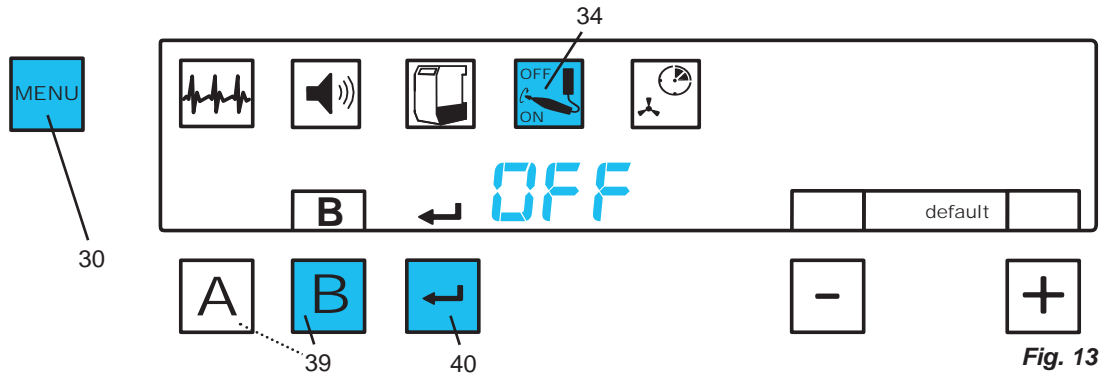

Fig. 13

The start-up threshold, the point at which the connected electrical appliance opens the suction hose, can be individually adjusted for each hose.

- ⇒ Press menu key (30) 4x
 - ◆ The start-up threshold symbol (34) blinks.
 - ◆ The letters A and B blink.
- ⇒ Press the suction hose button (39) of the suction which is to be adjusted
 - ◆ The letter of the selected hose is indicated.
 - ◆ The display shows „OFF“.
- ⇒ Switch the electrical appliance off. Units equipped with a stand-by mode should be switched to stand-by (e.g. in the case of a hand piece, only switch the controller on without activating the hand piece).
- ⇒ Press the enter button (40)

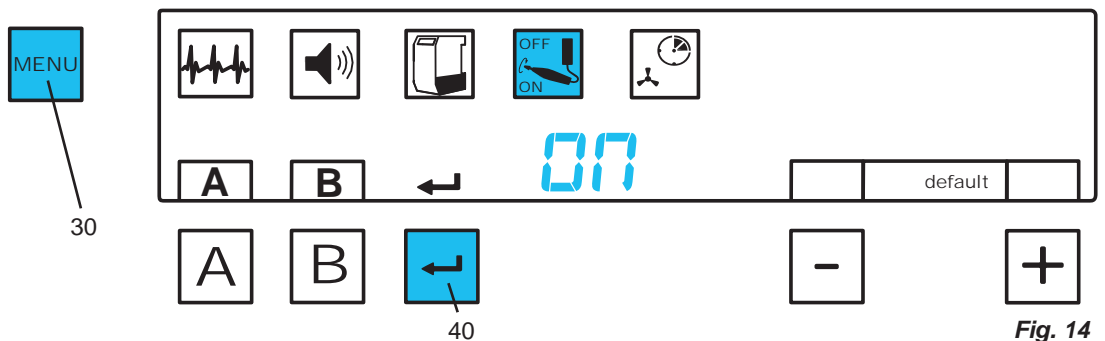

Fig. 14

- ◆ The display shows "ON".
- ⇒ Switch the electrical appliance on, e.g. activate the hand piece at the speed at which you require the suction hose to open.
- ⇒ Press the enter button (40).
- ⇒ Select the next suction hose which you would like to adjust, or quit this menu by pressing the menu key (30).



Before selecting a suction hose, press the \oplus/\ominus buttons together and the start-up threshold on both hoses will return to the factory set parameter (8 W).

5.3.5 Shut-Off Delay

Shut-off delay = the amount of time between switching the connected electrical appliance off and the closure of the respective suction hose (= pinch valve).

Two types of shut-off delay times can be distinguished, each of which can be set independently of one another:

- Only one of the two suction hoses, A OR B, is open:
Set the time, from when the pinch valve in the suction hose closes and the suction turbine shuts off (e.g. for targeted suction of residue dust)

- Both suction hoses, A AND B, are open:
Set the duration of time, until the pinch valve in the suction hose closes and the suction power for the other suction hose has readjusted.



Select a longer amount of time in order to prevent short interruptions (e.g. when working with a hand piece motor) from switching the extractor on and off too frequently, therefore causing the suction power to be continuously be readjusted.

⇒ Press the menu key (30) 5x

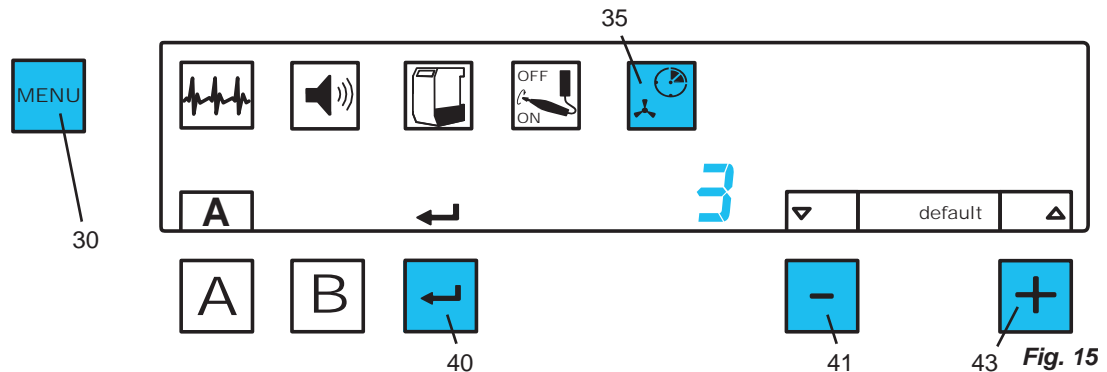

- ◆ The shut-off delay symbol (35) blinks.

Set shut-off delay A

- ◆ The letter A is indicated
- ◆ The display shows the current shut-off delay setting for suction hose A.

⇒ Set the required shut-off delay with the ⊕/⊖ buttons (41, 43)

⇒ Press enter button (40)

Set shut-off delay B

- ◆ The letter B is indicated
- ◆ The display shows the current shut-off delay setting for suction hose B.

⇒ Set the required shut-off delay with the ⊕/⊖ buttons (41, 43)

⇒ Press enter button (40)

Set shut off delay A and B

- ◆ The letters A and B are indicated
- ◆ The display shows the current shut-off delay setting.

⇒ Set the required shut-off delay with the ⊕/⊖ buttons (41, 43)

⇒ Press enter button (40)

The shut-off delay adjustment can be quit at any time before or after the value is saved, by pressing the menu key (30)



Whilst setting the shut-off delay, press the ⊕/⊖ buttons together to return to the factory set shut-off delay parameter.

6. Cleaning / Maintenance



Inside the extractor there are small parts which require maintenance. Opening the device, other than for the processes described below, is not permissible!

6.1 Replacing the Dust Bag

The set dust bag fill level has been reached:

- ◆ The dust drawer symbol (33, fig. 2) blinks.
- ◆ An audible signal will be emitted 3x
- ◆ The display blinks "Cod01".

Emptying the dust drawer:

- ⇒ Switch the extractor off.
- ⇒ Pull the front panel forward and off (5, Fig.1).
- ⇒ Pull the dust drawer (7) out towards the front.
- ⇒ Remove the protective film from the glue flap and use it to cover the dust bag opening!

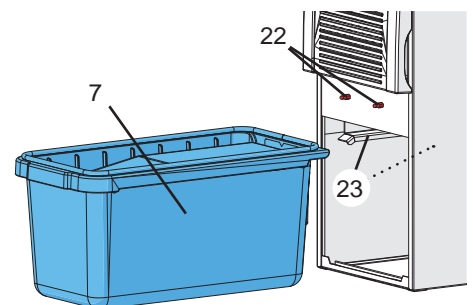

Fig. 16

- ⇒ Dispose of the dust bag properly.
- ⇒ Insert a new dust bag into the dust drawer. Ensure that the new dust bag is properly aligned in the guide grooves (21) and the glue flap faces upwards.



Use only original Renfert dust bags (see spare parts list).

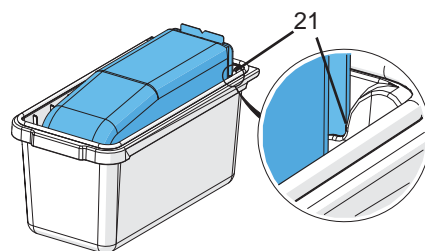

Fig. 17

- ⇒ Inspect the dust drawer seal for damage and replace it, as required (24)
- ⇒ Insert the dust drawer, making sure it is straight, and push it in as far as it will go. Make sure that the dust drawer is seated correctly on the guide (23, fig.16)
- ⇒ Install the front panel (5, fig.1) on the bottom hooks then push it into the upper lock bolts (22, fig.16), pressing firmly until it locks in place.

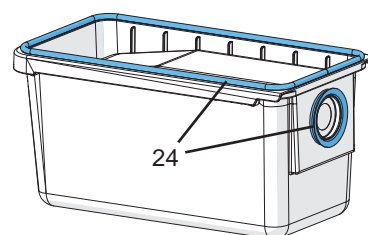

Fig. 18

6.2 Filters

The extractor contains a 2 level filter system comprising:

- dust bag
- fine particle filter



NEVER operate the dust extractor without the complete filtration system.



Use only the original Renfert filter (see spare parts list).

6.2.1 Replacing the Fine Particle Filter

Examine and replace the fine particle filter (6) on a regular basis, at least once a year. It must always be replaced if the dust drawer symbol (33, fig. 2) blinks, despite a new dust bag having just been replaced.

- ⇒ Pull the upper front panel (4, Fig.1) forward and off.
- ⇒ Turn the fine particle filter in an anti-clockwise direction to release it.
- ⇒ Pull the fine particle filter straight forwards and out of the unit and dispose of it properly.
- ⇒ Install a new fine filter and fully insert it over the holder bar (25).
- ⇒ Turn the fine particle filter in a clockwise direction and hand-tighten it in place.
- ⇒ Inspect the seal on the front panel for damage and replace it, as required.
- ⇒ Snap the front panel back in place.

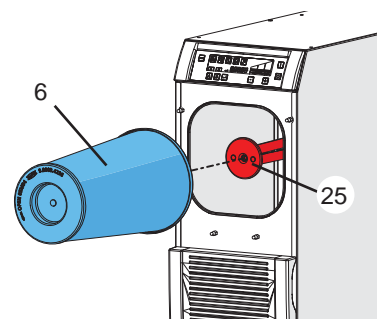

Fig. 19

6.2.2 Replacing the Exhaust Filter

The exhaust filter (26) primarily traps particles rubbed off the suction turbine graphite brushes. The filter should be replaced annually:

- ⇒ Remove the suction pipe (see chapter 4.5.1)
- ⇒ Press the lock tabs (4 pcs.) on the filter cassette (14) and pull the filter cassette off.
- ⇒ Dispose of the filter and filter cassette properly.
- ⇒ Insert a new filter mat in the filter cassette so that the smooth, compressed side of the filter mat faces down or outwards when the filter is installed.
- ⇒ Replace the new filter cassette with the new filter.
- ⇒ Make sure the filter cassette is properly seated and locked in place on all lock tabs.

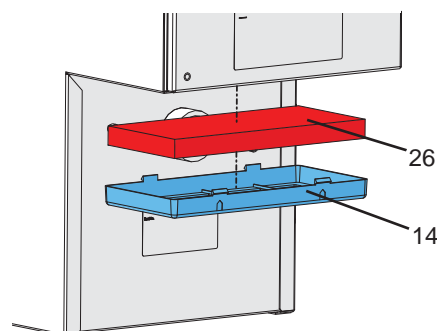

Fig. 20

6.2.3 Replacing the Electronics Filter

Cooling air for the unit's electronics passes through the electronics filter (11). The type of material trapped in the filter depends on the ambient laboratory conditions.

- ⇒ The filter should be examined annually and replaced as necessary:
- ⇒ Press on the lock tabs (2 pcs.) on the filter cassette (11) and pull the cassette off.
- ⇒ Dispose of the filter and filter cassette properly.
- ⇒ Insert a new filter in the filter cassette.
- ⇒ Re-install the new filter cassette with the new filter.
- ⇒ Make sure the filter cassette is properly seated and locked in place on both lock tabs.

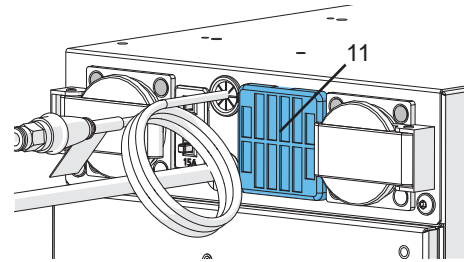

Fig. 21

6.2.4 Change Compressed filter

- ⇒ Disconnect the appliance from the compressed air supply.
- ⇒ Roll away the O-ring seal.
- ⇒ Unscrew filter housing (hold up at the filter housing with the screwdriver attached).
- ⇒ Using an Allan key (SW 5 mm) unscrew the sleeve (26).
- ⇒ Install a new piece of non-woven material (28) and sieve (27), making sure to adhere to the correct.
- ⇒ Screw the sleeve back in and hand-tighten.
- ⇒ Screw filter housing together, replace the O-ring seal.

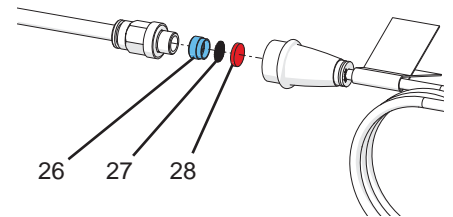

Fig. 22

6.3 Self-Diagnosis

If the self-diagnosis is activated (see chapter 5.3.1.), it will take place when the device is switched on. It checks important functions in the device.

This process takes approximately 30 seconds.



A blocked or defect suction hose can only be detected by the self-diagnosis and not when the device is in action.

If an error is detected during the self-diagnosis, a fault code (see chapter 7.1) will be displayed. Please continue as instructed.

6.4 Safety Mechanism

The extractor is safeguarded by two device overload switches (10).

If an overload switch is released, it can be reset by pressing the button back in.



If the protection switch is repeatedly released, this shows the device has a fault.

Send the device to be repaired!

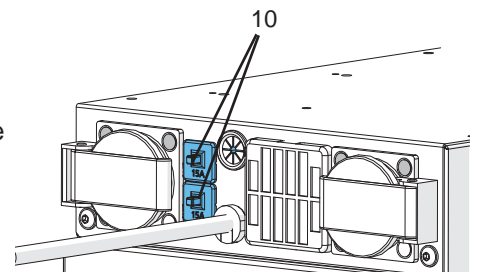

Fig. 23

6.5 Factory Set Parameter

When the function "reset to factory set parameter" is activated, all individually set information is lost and overwritten by factory set values.

- ⇒ Extraction off
- ⇒ ⊕ and ⊖ Press button (41, 43) and keep pressed
- ⇒ Extraction on
- ⇒ ⊕ and ⊖ Press button (41, 43) and keep pressed
 - ◆ An audible signal will confirm the factory set parameter is saved and the display will indicate „rES“

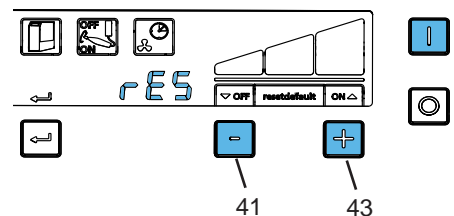

Fig. 24

Factory set parameter:

Function / Feature	Adjustment Range	Factory Parameter
Extraction force, one suction hose is open	1 - 3	2
Extraction force, both suction hoses are open	1 - 3	2
Sensitivity of dust bag fill level Recognition	1 - 9	5
Diagnosis - mode (after switching on)	On / Off	Off
Audible Signal	On / Off	Off
Automatic start-up threshold	1- 100 W	8 W
Shut-off delay A or B, one suction hose is open	3 - 30 Sec.	3 Sec.
Shut-off delay, A/B both Suction hoses are open	3 - 30 Sec.	15 Sec.

6.6 Spare Parts

For the order numbers of consumables and spare parts please refer to the spare parts list at the end of this manual.

Serial numbers, manufacture date and device type can be found on the device identification plate.

7. Troubleshooting

Error	Possible Cause	Corrective Action
Extractor stops suddenly for no apparent reason and a error code is indicated in the display	<ul style="list-style-type: none"> An error has been detected. 	<ul style="list-style-type: none"> See table "Error Codes" If the instructions are of no help to you, or the error code is not listed: <ul style="list-style-type: none"> - Make a note of the error code. - Send the device in for repair. - Inform the repair service which error code was noted.
Dust bag over full	<ul style="list-style-type: none"> Sensitivity of "dust bag full" signal is too large 	<ul style="list-style-type: none"> Set a smaller value (See chapter 5.3.3)
"Dust bag full" indicator goes on, even though the bag is not full	<ul style="list-style-type: none"> Sensitivity of "dust bag full" signal is too low 	<ul style="list-style-type: none"> Set a larger value (See chapter 5.3.3)
Suction hose cannot be closed by pressing the suction hose button	<ul style="list-style-type: none"> An electrical appliance which is connected to the suction hose is still in operation. 	<ul style="list-style-type: none"> Switch the connected electrical appliance off.
"Dust bag full" indicator appears shortly after having replaced the dust bag	<ul style="list-style-type: none"> Fine particle filter is blocked Suction hose blocked Cross-section of the dust generating device's hose fitting is too small. 	<ul style="list-style-type: none"> Replace the fine particle filter (Chapter 6.2.1) Remove the obstruction in the suction hose Reset the sensitivity of the "dust bag full" indicator (Chapter 5.3.3)..
Extractor fails to start when a dust generating device is being used.	<ul style="list-style-type: none"> Extractor is not switched on. Device fuse has blown. Dust generating device is not connected to the extractor socket. Start-up threshold of the suction hose is too high. 	<ul style="list-style-type: none"> Switch the extractor on (Chapter 5.1). Check and reinstall the fuse if necessary (Chapter 6.4). Connect the dust generating device to the coupler socket (Chapter 4.7). Adjust start-up threshold (Chapter 5.3.4)

Error	Possible Cause	Corrective Action
Extractor starts, although a connected device is not being used.	<ul style="list-style-type: none"> Start-up threshold of one suction hoses is too low. 	<ul style="list-style-type: none"> Check, which suction hose is open, the relevant letter will be indicated in the display. Adjust the start-up threshold of the suction hose (Chapter 5.3.4).
Extractor fails to stop when a connected device is switched off	<ul style="list-style-type: none"> The dust generating device is not plugged in to the coupler socket on the extractor and the suction hose button is switched on. Start-up threshold is too low Shut-off delay is too long. 	<ul style="list-style-type: none"> Switch the suction hose button on the extractor off, and connect the dust generating device to the coupler socket on the extractor (Chapter 4.7). Adjust start-up threshold (Chapter 5.3.4) Set shorter shut-off delay (Chapter 5.3.5).
No satisfactory setting for the automatic start-up feature can be adjusted.	<ul style="list-style-type: none"> Some older hand pieces do not generate a sufficiently strong signal for the automatic start-up feature. 	<ul style="list-style-type: none"> Switch to higher revs per minute (e.g. 10,000 rpm.)
Panels covering the fine particle filter and the dust drawer are difficult to open.	<ul style="list-style-type: none"> Lock bolts are dirty. 	<ul style="list-style-type: none"> Clean lock bolts and lubricate them slightly if necessary.
The extraction force is not readjusted when a second suction hose is switched on or off	<ul style="list-style-type: none"> The automatic extraction force readjustment is deactivated. 	<ul style="list-style-type: none"> Activate the automatic extraction force readjustment (See chapter 5.2.2).
The display indicates "OFF" above the button  (41)	<ul style="list-style-type: none"> The automatic extraction force readjustment is deactivated. 	<ul style="list-style-type: none"> Activate the automatic extraction force readjustment if required (See chapter 5.2.2).
There is no audible signal.	<ul style="list-style-type: none"> The audible signal is deactivated. 	<ul style="list-style-type: none"> Activate audible signal (Chapter 5.3.2)
Pinch valves close / open slowly	<ul style="list-style-type: none"> The filter in the compressed air connection is blocked 	<ul style="list-style-type: none"> Change the filter in the compressed air connection (see chapter 6.2.4).

7.1 Error codes

If the following error code appears during operation or self-diagnosis, please continue as follows:

- ⇒ Switch device off
- ⇒ Deal with the fault as described in the table
- ⇒ Switch the device back on

For all other error codes, switch the unit off and then back on again.

If the error code is repeatedly indicated:

- ⇒ Make a note of the error code.
- ⇒ Contact the repair service

Error Code	Cause / Meaning	Corrective Action
Cod01	<ul style="list-style-type: none"> The set dust bag fill level has been reached. 	<ul style="list-style-type: none"> Change dust bag (Chapter 6.1).
Err01	<ul style="list-style-type: none"> Suction flow is blocked Insufficient compressed air pressure 	<ul style="list-style-type: none"> Check the suction hoses for blockages, examine the dust bag fill level, and change if necessary (See chapter 6.1), examine the fine particle filter for contamination, and change if necessary (see chapter 6.2.1). If the device is supplied with compressed air from a main laboratory switch together with the air compressor, then at first the compressed air will be insufficient and the self-diagnosis will indicate a fault. Switch the device ON at the On /Off switch (3, fig.1).
Err04	<ul style="list-style-type: none"> Overheated electronics 	<ul style="list-style-type: none"> Switch the extractor off and allow cooling. If the extractor is located in a closed cabinet, make sure the exhausted air is able to escape (See chapter 4.2).

Error Code	Cause / Meaning	Corrective Action
Err22	• Suction hose A blocked or defect.	• Make sure the suction line and pinch valve in the suction hose are not blocked.
Err23	• Suction hose B blocked or defect.	
Err26	• Suction hose A or B permanently open.	• Make sure the pinch valve on the suction hose is not blocked that the pinch valve membrane is not defect. • Check to ensure that the pinch valve is assembled correctly.
Err51	• Error occurred whilst adjusting the start-up threshold.	• Cancel the adjustment of the start-up threshold using the menu key (30, fig. 2) and enter the required setting afresh as described in Chapter 5.3.4

EN

8. Technical Data

Working Voltage	230 V	120 V
Permissible mains voltage	220 - 240 V	120 V
Mains frequency	50/60 Hz	60 Hz
Suction turbine power *)	1400 W	1400 W
max. connecting power *)	2000 W	360 W
Total connected power *)	3400 W	1800 W
Mains input fuse	2x 15 A (T)	
max. connection pressure	8 bar [116 psi]	
min. connection pressure	4,5 bar [65 psi]	
LpA **) (at max. volume flow)	59 dB(A)	
Number of suction hoses	2	
Volume flow, max per suction hose ***)	3300 l/min	
Vacuum pressure, max	20 kPa [2,9 psi]	
Fine particle filter:		
Filter surface area	ca. 0.8 m ² [ca. 1240 sq inch]	
Filterquality	Class M according to EN60335-2-69	
Fill volume, dust bag	ca. 7,5 l [2 US Gallonen]	
Dimensions (height x width x depth)	595 x 225 x 565 mm [23,4 x 8,8 x 22,2 inch]	
Weight (empty)	ca. 27 kg [ca. 59,5 lbs]	
Ø Suction fittings:		
Internal	45 mm [1,77 inch]	
External	50 mm [1,97 inch]	

*) Working voltage power

**) Sound pressure levels according to EN ISO 11202

9. Warranty



There is a guarantee on the suction motor for 800 working hours (motor running time)..

Provided the unit is properly used, Renfert warrants all components for **3 years**.

Warranty claims may only be made upon presentation of the original sales receipt from the authorized dealer. Components subject to natural wear as well as consumables e.g. filters, pinch valve, seals, motor, etc. ...) are excluded from this warranty.

The warranty is voided in the case of improper use; failure to observe the operating, cleaning, maintenance and connection instructions; in case of independent repairs or repairs by unauthorized personnel; if spare parts from other manufacturers are employed, or in case of unusual influences or influences not in compliance with the utilization instructions.

Warranty service shall not extend the original warranty.

10. Disposal Information

10.1 Disposing of Consumables

Full dust bags and filters must be disposed of under compliance with locally applicable regulations. Depending on the material trapped by the filters, protective gear may need to be worn during disposal.

10.2 Disposing of the Unit

The unit must be disposed of by an authorized recycling operation. The selected firm must be informed of all possible health hazardous residues in the unit.

10.2.1 Disposal Instructions for countries in the EU

To conserve and protect the environment, prevent environmental pollution and improve the recycling of raw materials, the European Commission adopted a directive that requires the manufacturer to accept the return of electrical and electronic units for proper disposal or recycling. Within the European Union, units with this symbol should not therefore be disposed of in unsorted domestic waste.



Please contact your local authorities for more information on proper disposal.